

Katalog náhradních dílů pro
průmyslový šicí stroj

GARUDAN[®]

GP-130 serie

GP-230 serie



ANITA B, s.r.o.

Průmyslová 2453/7

680 01 Boskovice

Czech Republic

tel: +420 515 553 628

+420 515 553 621

fax: +420 515 553 626

e-mail: info@anita.cz

A. Arm bed and its accessories

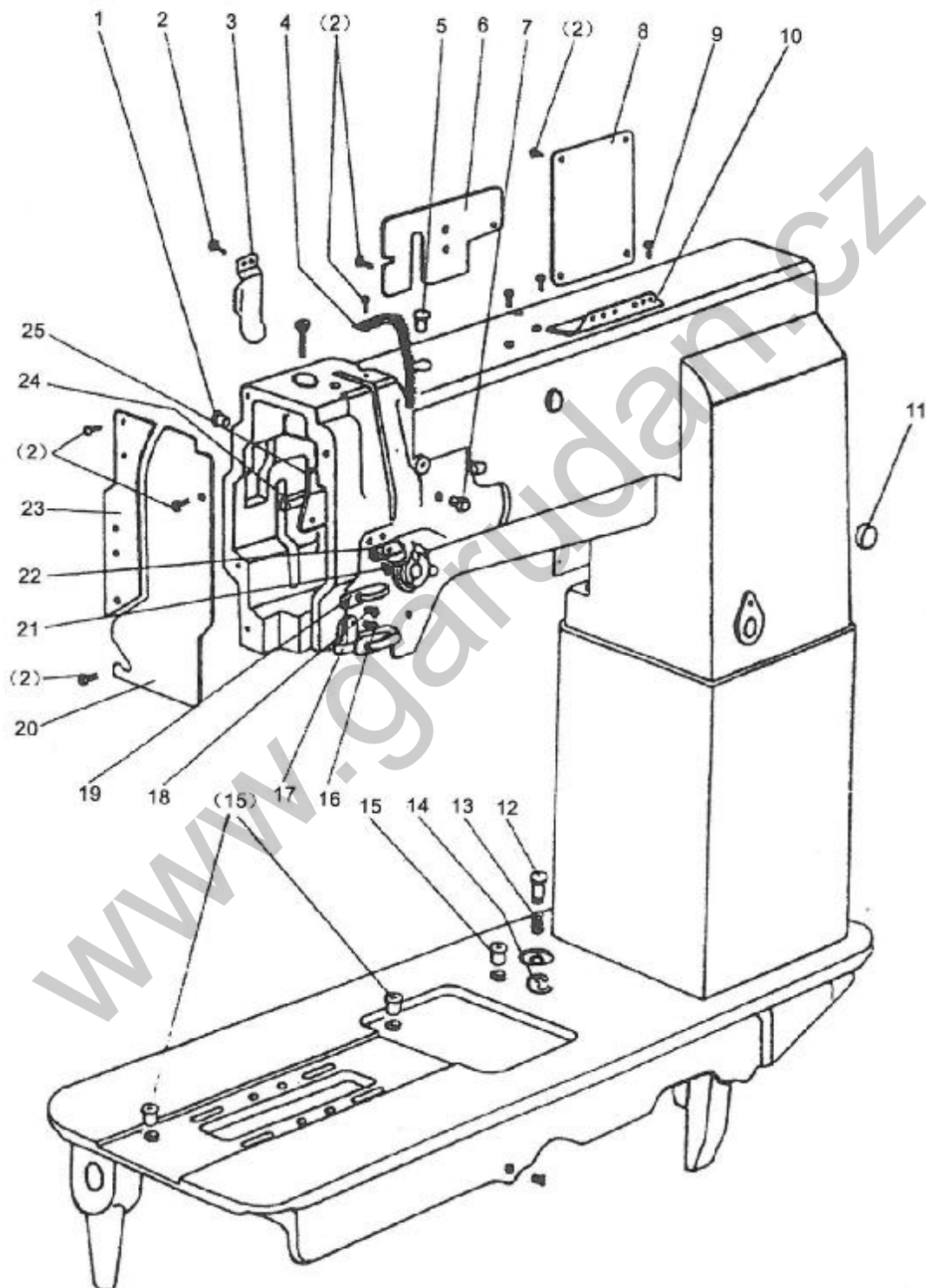

A. Arm bed and its accessories

Fig. No.	Part No.	Description	CP-230-445 MH	CP-130-113 MH	Remark
A01	70216036	Rubber plug	2	2	
A02	70515160	Screw	30	30	11/64 (40) × 9
A03	70211038	Oil guard plate	1	1	
A04	70211039	Thread take-up cover	1	1	
A05	70216037	Rubber plug	1	1	
A06	70211040	Slide cover(left)	1	1	
A07	70216038	Rubber plug	1	1	
A08	70211041	Slide cover(right)	1	1	
A09	70215116	Screw	2	2	11/64 (40) × 8
A10	70214012	Thread guide plate	1	1	
A11	70216039	Rubber plug	1	1	
A12	70210047	Reposition button	1	1	
A13	70217046	Reposition spring	1	1	
A14	70218039	Ring	1	1	
A15	70216040	Oil cap	2	2	
A16	70215212	Screw	1	1	9/64 (40) × 6.5
A17	70214001	Thread guide finger (lower) Assy.	1	1	
A18	70215214	Screw	1	1	9/64 (40) × 4.5
A19	70214020	Thread guide finger (middle)	1	1	
A20	70211042	Face plate	1	1	
A21	70215114	Screw	2	2	3/16 (28) × 12.1
A22	70214011	Thread guide finger (upper)	1	1	
A23	70211043	Guide mounting block	1	1	
A24	70212012	Plate for oil guard	1	1	
A25	70211044	Oil guard	1	1	

B.Thread tension regulator mechanism

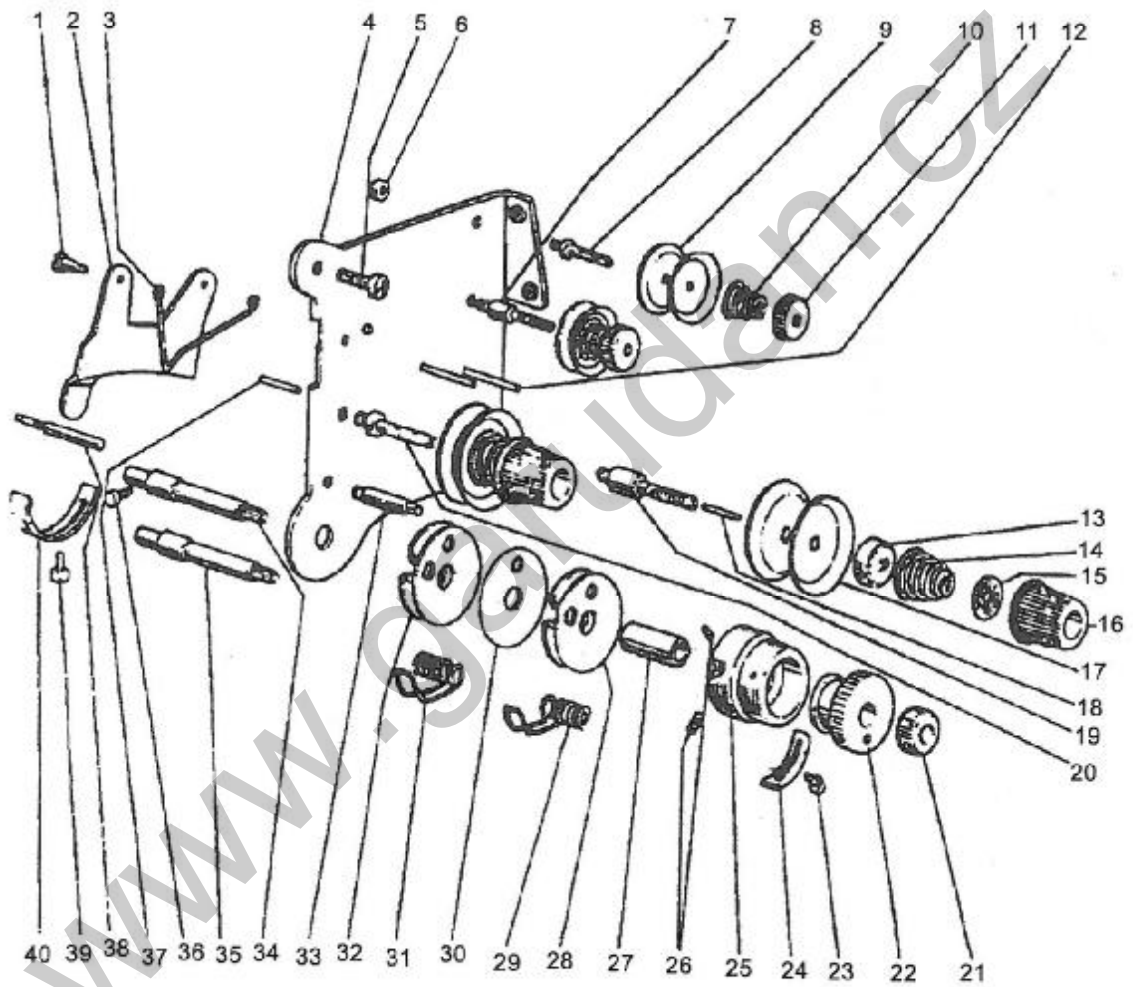

B.Thread tension regulator mechanism

Fig. No.	Part No.	Description	GP-250-443 MH	GP-158-443 MH	Remark	
B01	70215121	Screw	2	2	9/64 (40) ×3	
B02		Tension releasing plate	1	1		
B03		Tension releasing spring	1	1		
B04		Mounting plate	1	1		
B05		Screw	2	2	11/64 (40) ×8	
B06		Nut	2	2		
B07		Thread tension stud	1		11/64 (40) ×14	
B08		Thread tension stud	1	1	11/64 (40) ×14	
B09		Thread tension disk	4	2		
B10		Thread tension spring	2	1		
B11		Thread tension nut	2	1		
B12		Pin	3	2		
B13		Tension releasing plate	2	1		
B14		Thread tension spring	2	1		
B15		Thumb nut stop plate	2	1		
B16		Thumb nut Assy.	2	1		
B17		Thread tension disk	4	2		
B18		Pin	1			
B19		Thread tension stud	1		1/4 (40) ×23	
B20		Thread tension stud	1	1	1/4 (40) ×23	
B21		Nut	1	1		
B22		Bushing	1			
B23		Screw	1		9/64 (40) ×6	
B24		Stop block	1			
B25		Guide block	1			
B26		Screw	2		1/8 (44) ×3.9	
B27		Bushing	1			
B28		Tension releasing plate Assy.	1			
B29		Thread take-up spring	1			
B30		Tension releasing plate Assy.	1			
B31		Thread take-up spring	1	1		
B32		Tension releasing plate Assy.	1	1		
B33		Screw	1		9/64 (40) ×2.9	
B34		Screw		1	9/64 (40) ×2.9	
B35		Screw	1		1/4 (40) ×38.5	
B36		Screw		1	1/4 (40) ×14.5	
B37		70215215	Screw	1	1	11/64 (40) ×10
B38			Pin	1	1	
B39		70210040	Tension releasing pin	1	1	
B40			Screw	1	1	9/64 (40) ×6.5
B41		70214002	Stop block	1	1	

C.Upper shaft mechanism

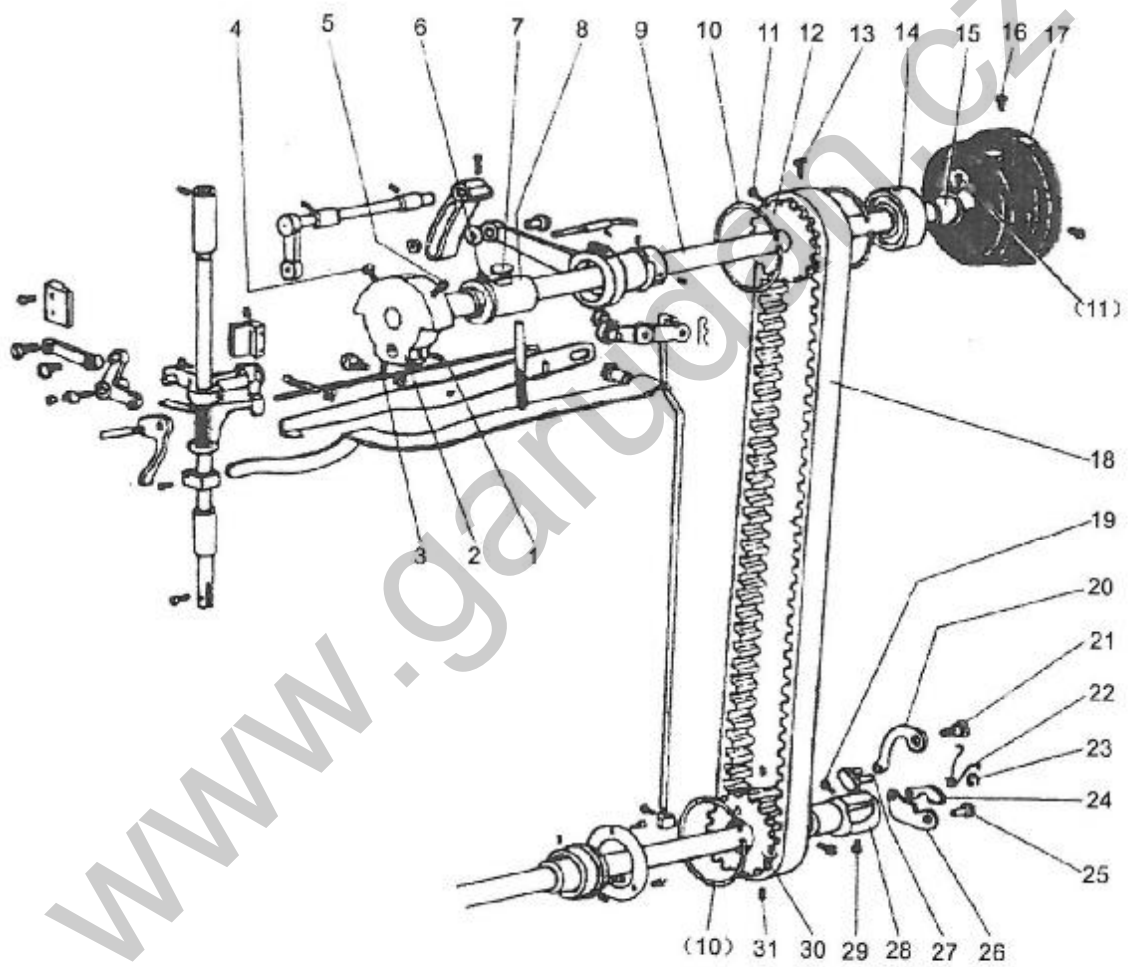

C.Upper shaft mechanism

Fig. No.	Part No.	Description	GP-230-443 MH	GP-130-443 MH	Remark
C01	70215123	Screw	1	1	1/4 (40) × 6
C02	70206017	Needle bar crank	1	1	
C03	70215122	Screw	1	1	1/4 (40) × 4
C04	70215124	Screw	1	1	9/32 (28) × 13
C05	70215125	Screw	1	1	9/32 (28) × 14
C06	70215216	Screw	1	1	1/4 (24) × 13
C07		Felt	1	1	
C08	70208068	Upper shaft bushing(left)	1	1	
C09	70203038	Upper shaft	1	1	
C10	70217035	Spring flange	3	3	
C11	70215128	Screw	1	1	15/64 (28) × 8.5
C12	70207032	Synchronous pulley	1	1	
C13	70215133	Screw	1	1	15/64 (28) × 14.5
C14	70204008	Bearing	1	1	
C15	70208069	Collar	1	1	
C16	70215128	Screw	2	2	15/64 (28) × 12
C17	70207022	Pulley wheel	1	1	
C18	70207090	Synchronous belt	1	1	
C19	70215219	Tighten screw	1	1	15/64 (28) × 10
C20	70205032	Long lever	1	1	
C21	70210041	Long lever pin	1	1	
C22	70217036	Spring	1	1	
C23	70218048	E-ring	1	1	
C24	70205034	Lever	1	1	
C25	70210042	Short lever pin	1	1	
C26	70205035	Short lever	1	1	
C27	70205033	Pin	1	1	
C28	70210043	Synchronous pulley shaft	1	1	
C29	70215218	Screw	1	1	15/64 (28) × 10.5
C30	70207034	Synchronous pulley	1	1	
C31	70215145	Screw	2	2	15/64 (28) × 4.5

D.Presser foot mechanism

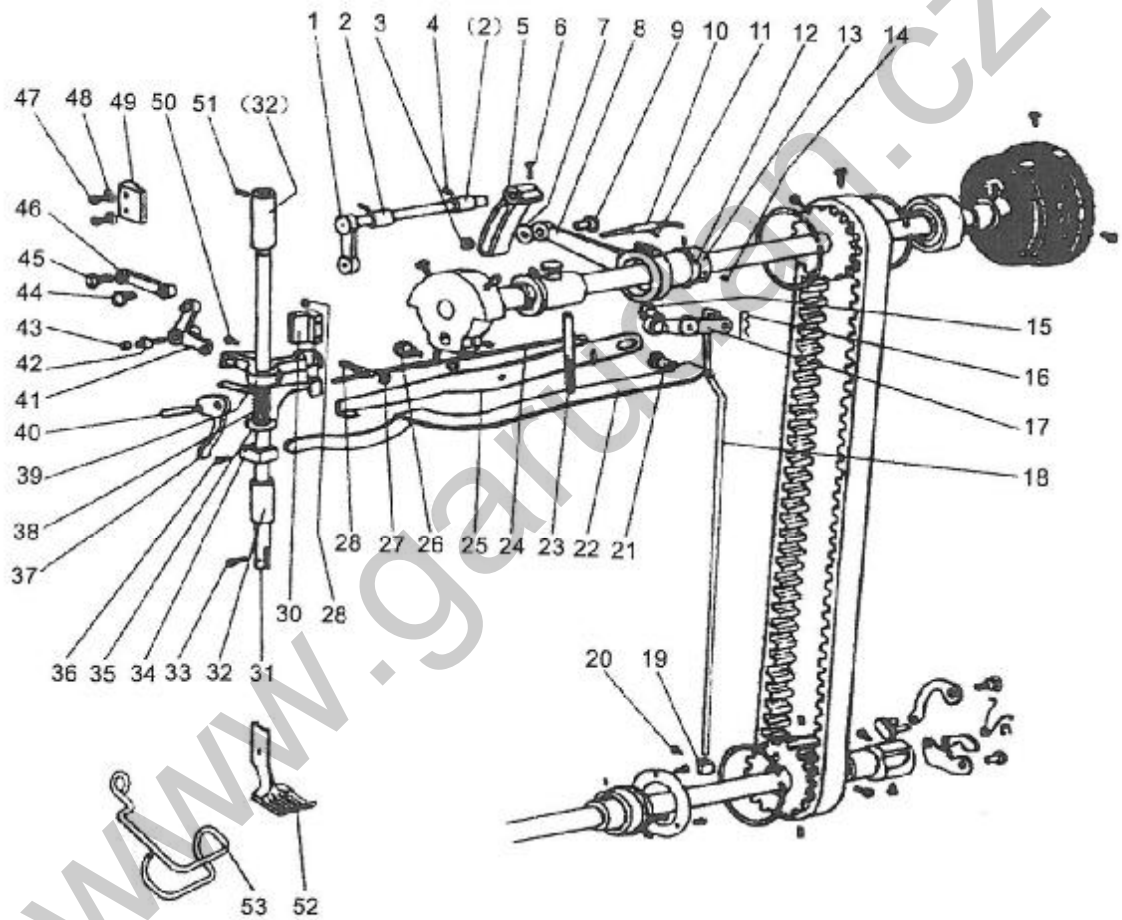

D.Presser foot mechanism

Fig. No.	Part No.	Description	CP-250-443 MEH	CP-130-443 MEH	Remark
D01	70203039	Presser foot lifting crank shaft	1	1	
D02	70208070	Presser foot lifting crank shaft bushing	2	2	
D03	70215263	Nut (M6 x 0.75)	1	1	(M6×0.75)
D04	70215220	Screw	2	2	1/4 (24) × 7
D05	70206018	Adjustive crank	1	1	
D06	70215221	Adjustive crank screw	1	1	1/4 (28) × 16
D07	70218049	Washer	1	1	
D08	70205036	Eccentric wheel connecting rod	1	1	
D09	70215259	Adjustive screw	1	1	
D10		Oil wick	1	1	
D11	70217020	Eccentric connecting rod felt clamp	1	1	
D12	70218050	C-ring	1	1	
D13	70206019	Eccentric wheel	1	1	
D14	70215123	Eccentric wheel screw	2	2	1/4 (40) × 6
D15	70215228	Connection rod screw	1	1	1/4 (24) × 14
D16	70217041	Pin	1	1	
D17	70205050	Knee lifting connecting rod Assy.	1	1	
D18	70217040	Knee lifting tie rod	1	1	
D19	70209018	Knee lifting tie rod ringer	1	1	
D20	70215152	Ringer screw	1	1	11/64 (40) × 5.5
D21	70215227	Screw	1	1	1/4 (24) × 17
D22	70217039	Spring	1	1	
D23	70215226	Screw	1	1	15/64 (28) × 79
D24	70217037	Knee lifting lever reposition spring	1	1	
D25	70217038	Knee lifting lever	1	1	
D26	70215225	Knee lifting lever screw	1	1	1/4 (24) × 7
D27	70215264	Reposition spring screw cap	1	1	
D28	70215224	Reposition spring screw	1	1	1/4 (24) × 19
D29	70215146	Guide rail screw	2	2	11/64 (40) × 12
D30	70212029	Guide rail	1	1	
D31	70203040	Presser bar	1	1	
D32	70208072	Bushing	2	2	
D33	70215230	Screw	1	1	1/8 (44) × 9
D34	70212030	Spring bracket	1	1	
D35	70217043	Push plate	1	1	
D36	70215231	Screw	1	1	9/64 (40) × 8.5
D37	70205039	Presser foot lifting spanner	1	1	
D38	70217042	Spring	1	1	
D39	70205040	Presser bar lifting bracket	1	1	
D40	70215232	Presser foot spanner screw	1	1	11/64 (40) × 8.5
D41	70205037	Presser foot lifting level	1	1	
D42	70210044	Feeding crank guide post shaft	1	1	3/16 (28) × 10
D43	70208071	Slide post	1	1	

D.Presser foot mechanism

Fig. No.	Part No.	Description	GP-200-423 MH	GP-130-423 MH	Remark
D44	70215222	Crank connecting rod screw	1	1	11/64 (32) × 6
D45	70215223	Screw	1	1	1/4 (40) × 5
D46	70205038	Crank connecting rod	1	1	
D47	70215160	Screw	2	2	11/64 (40) × 10
D48		Washer	2	2	
D49	70212028	Slide block guide rail	1	1	
D50	70215147	Screw	1	1	11/64 (40) × 17.5
D51	70215220	Tighten screw	2	2	1/4 (24) × 13
D52		Walking foot		1	
D52	70202046	Walking foot(1/2)	1		1/2
D52	70202126	Walking foot(3/8)	1		3/8
D52	70202127	Walking foot(3/16)	1		3/16
D53		Presser foot protection cover	1	1	

E. Needle bar thread take-up mechanism

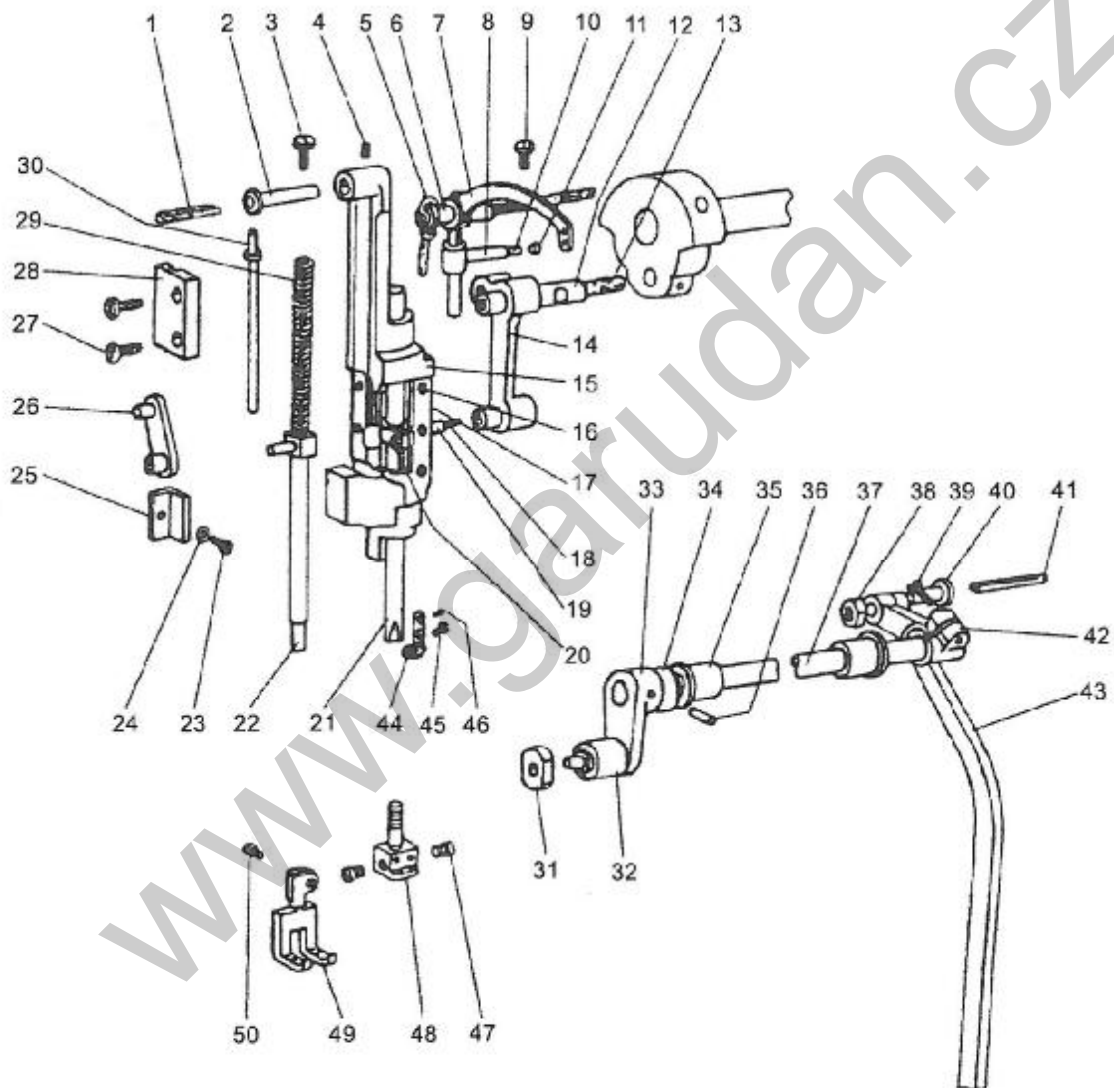

E. Needle bar thread take-up mechanism

Fig. No.	Part No.	Description	CP-230-43 MH	CP-136-43 MH	Remark
E01		Oil wick	1	1	
E02	70210045	Needle bar vibrating bracket pin	1	1	
E03	70215233	Screw	1	1	5/26 (28) × 10.4
E04	70215217	Screw	1	1	15/64 (28) × 10
E05		Oil wick	1	1	
E06	70210018	Thread take-up lever hinge shaft	1	1	
E07	70205041	Thread take-up lever	1	1	
E08	70205042	Slide rod	1	1	
E09	70215128	Screw	1	1	15/64 (28) × 12
E10		Oil wick	1	1	
E11		Plug	1	1	
E12	70210019	Thread take-up crank connecting rod shaft	1	1	
E13		Oil wick	1	1	
E14	70205043	Needle bar thread take-up connecting rod	1	1	
E15	70213021	Needle bar vibrating bracket	1	1	
E16	70215234	Screw	6	6	3/32 (56) × 4
E17	70211045	Washer	2	2	
E18		Felt	1	1	
E19	70202035	Needle bar clamp	1	1	
E20	70215222	Screw	1	1	9/64 (40) × 8.5
E21	70203044	Needle bar	1		
E21	70203041	Needle bar		1	
E22	70203042	Presser bar	1	1	
E23	70215260	Bolt	1	1	
E24	70218057	Washer	1	1	
E25	70212031	Needle bar guide block	1	1	
E26	70205044	Connecting rod	1	1	
E27	70215147	Screw	2	2	11/64 (40) × 17.5
E28	70212032	Slide block guide rail	1	1	
E29	70217044	Spring	1	1	
E30	70210046	Presser spring level	1	1	
E31	70212033	Needle bar bracket vibrating slide block	1	1	
E32	70215254	Screw	1	1	15/64 (28) × 10
E33	70206020	Needle bar bracket vibrating crank (left)	1	1	
E34	70209016	Washer	1	1	
E35	70208073	Needle bar bracket vibrating shaft bushing	2	2	
E36	70210012	Pin	1	1	
E37	70203043	Needle bar bracket vibrating crank shaft	1	1	
E38	70215265	Nut	1	1	
E39	70215221	Screw	1	1	1/4 (24) × 16
E40	70215236	Screw	1	1	5/16 (24) × 5
E41		Oil wick	1	1	
E42	70206030	Needle bar bracket vibrating crank (right)	1	1	

E. Needle bar thread take-up mechanism

Fig. No.	Part No.	Description	GP-239-443 MH	GP-130-443 MH	Remark
E43		Needle bar bracket connecting rod	1	1	
E44	70214021	Lower thread guide		1	
E45	70215118	Screw		1	1/8 (44) × 4.5
E46	70215229	Screw		1	3/32 (56) × 2.5
E47		Screw	2		9/64 (40) × 3
E48	70202122	Needle clamp (3/8")	1		3/8
E48	70202123	Needle clamp (3/16")	1		3/16
E48	70202044	Needle clamp (1/2")	1		1/2
E49	70202124	Presser foot (3/8")	1		3/8
E49	70202125	Presser foot (3/16")	1		3/16
E49	70202045	Presser foot (1/2")	1		1/2
E49	70202042	Presser foot (single needle)		1	
E50		Screw	1	1	11/64 (40) × 7

F. Stitch length regulator mechanism

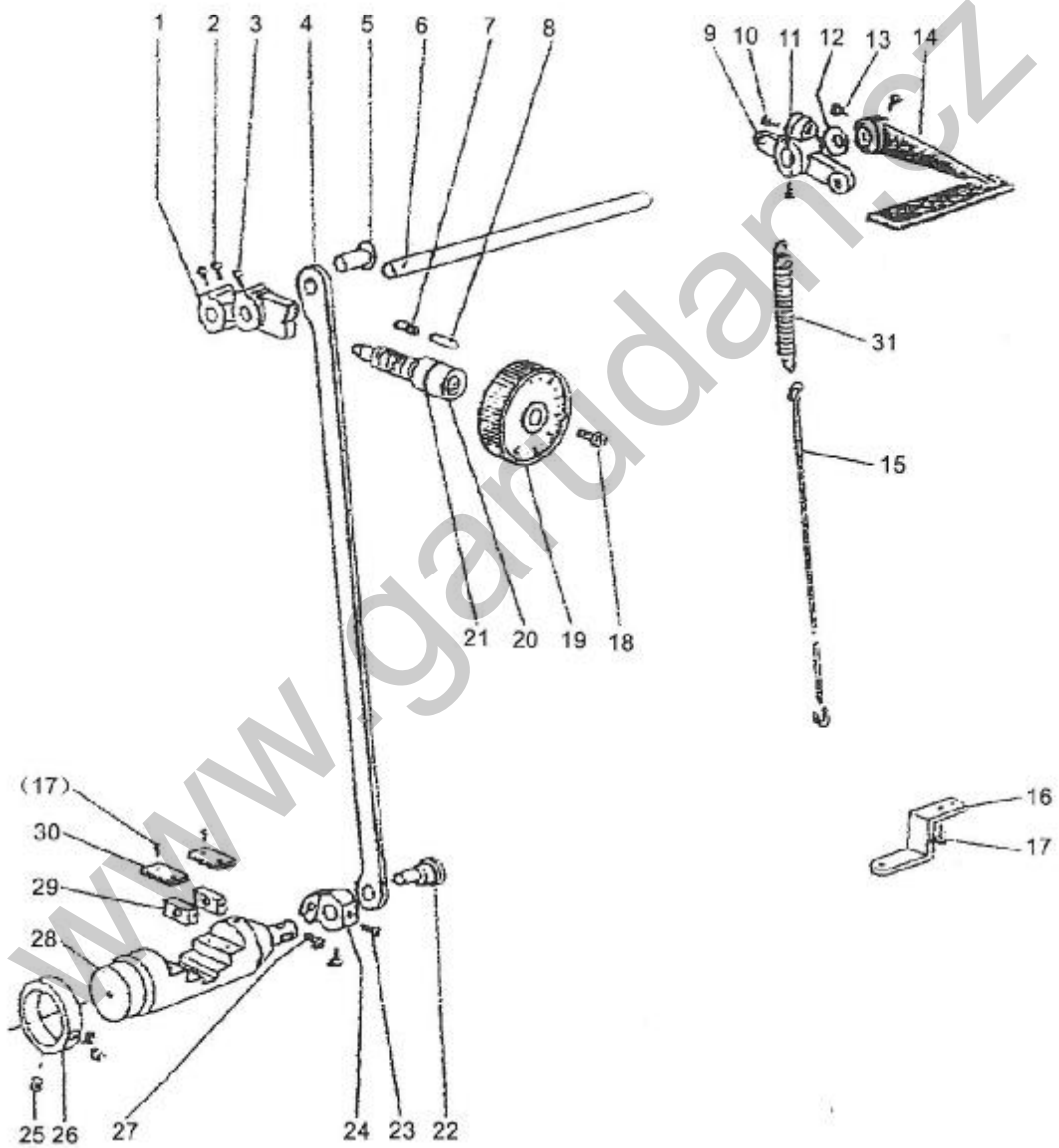

F. Stitch length regulator mechanism

Fig. No.	Part No.	Description	GP-230-443 MH	GP-130-443 MH	Remark
F01	70206028	Stitch length adjustable vibrating rod	1	1	
F02	70215237	Screw	2	2	15/64 (28) × 8.5
F03	70215238	Screw	1	1	15/64 (28) × 12
F04	70205111	Connecting rod	1	1	
F05	70210050	Eccentric shaft	1	1	
F06	70203046	Back stitch control level	1	1	
F07	70217022	Stitch length button spring	1	1	
F08	70210052	Stop pin	1	1	
F09	70206021	Back stitch control crank	1	1	
F10	70215239	Screw	1	1	15/64 (28) × 13.5
F11	70215121	Screw	1	1	11/64 (40) × 8.5
F12	70218036	Washer	1	1	
F13	70215219	Screw	2	2	15/64 (28) × 8.5
F14	7020504501	Back stitch control spanner	1	1	
F15	70217181	Back stitch control crank tie rod	1	1	
F16	70212034	Spring bracket	1	1	
F17	70215160	Screw	4	4	11/64 (40) × 8
F18	70215240	Screw	1	1	3/16 (28) × 8.6
F19	70216035	Stitch length scale	1	1	
F20	70205046	Screw	1	1	T7/16 (8) × 54.3
F21	70218051	O-ring	1	1	
F22	70210051	Feeding crank hinge shaft	1	1	
F23	70215056	Screw	2	2	M5×6
F24	70206031	Back stitch control crank (lower)	1	1	
F25	70215145	Screw	2	2	
F26	70209017	Ring	1	1	
F27	70215053	Screw M5 × 14	1	1	M5×14
F28	70213022	Back stitch saddle	1	1	
F29	70212035	Slide block	2	2	
F30	70212036	Guide plate	2	2	
F31	70217045	Back stitch control crank spring	1	1	

G.Lower shaft & feeding shaft mechanism

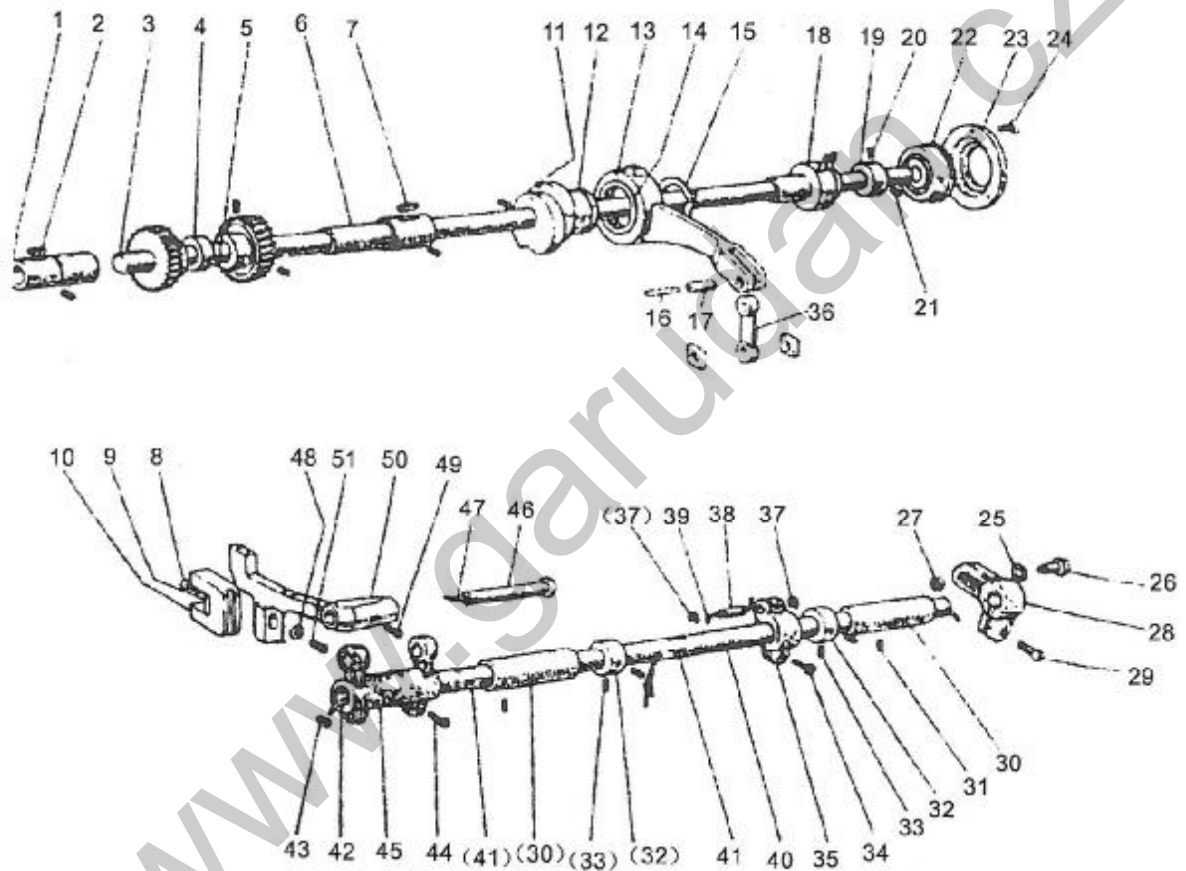

G.Lower shaft & feeding shaft mechanism

Fig. No.	Part No.	Description	CP-230-40 MH	CP-136-443 MH	Remark
G01	70208074	Lower shaft bushing (left)	1	1	
G02		Oil wick	1	1	
G03	70203047	Lower shaft	1	1	
G04	70206022	Feed eccentric cam	1	1	
G05	70215122	Tighten screw	1	1	1/4 (40) ×5
G06	70208075	Lower shaft bushing (right)	1	1	
G07		Oil wick	1	1	
G08	70215255	Screw	1	1	1/8 (44) ×4
G09		Felt	1	1	
G10	70505049	Feed bar fork	1	1	
G11	70515241	Screw	2	2	15/64 (28) ×14
G12	70206023	Feed cam	1	1	
G13	70205047	Feed cam connecting rod	1	1	
G14	70204022	Bearing	1	1	
G15	70218053	C-ring	1	1	
G16		Oil wick	1	1	
G17	70210048	Feed cam connecting rod pin	1	1	
G18	70208026	Lower shaft bushing (middle) Assy.	1	1	
G18-1	70216044	Lower shaft bushing copper oil tube	1	1	
G19	70208077	Bushing	1	1	
G20	70215217	Screw	1	1	
G21	70215122	Tighten screw	1	1	1/4 (40) ×4
G22	70204013	Bearing	1	1	
G23	70211046	Bearing holder	1	1	
G24	70215242	Screw	3	3	9/64 (40) ×7
G25	70218049	Tighten screw	1	1	
G26	70215261	Bearing	1	1	
G27	70215263	Bearing holder	1	1	
G28	70206024	Screw	1	1	
G29	70215221	Washer	1	1	1/4 (24) ×16
G30	70208078	Screw	2	2	
G31	70215220	Nut	2	2	1/4 (24) ×13
G32	70209014	Feed crank (right)	2	2	
G33	70215122	Screw	4	4	
G34	70215221	Feed shaft bushing (left)	1	1	1/4 (24) ×16
G35	70206025	Screw	1	1	
G36	70205048	Collar	1	1	
G37	70218039	Screw	2	2	
G38	70210049	Screw	1	1	
G39		Feed crank (middle)	1	1	
G40	70203048	Connecting rod	1	1	
G41		Ring	2	2	
G42		Connecting rod pin	1	1	

G.Lower shaft & feeding shaft mechanism

Fig. No.	Part No.	Description	GP-230-443 MH	GP-130-443 MH	Remark
G43		Oil wick clamp	1	1	
G44	70215243	Screw	2	2	3/16 (28) × 12
G45	70206026	Feed bar crank	1	1	
G46	70210050	Feed bar crank shaft	1	1	
G47		Oil wick	1	1	
G48	70218049	Washer	1	1	
G49	70215115	Screw	1	1	11/64 (40) × 7
G50	70213028	Feed bar	1	1	
G51	70215262	Screw	1	1	15/64 (28) × 17

H.Hook saddle mechanism

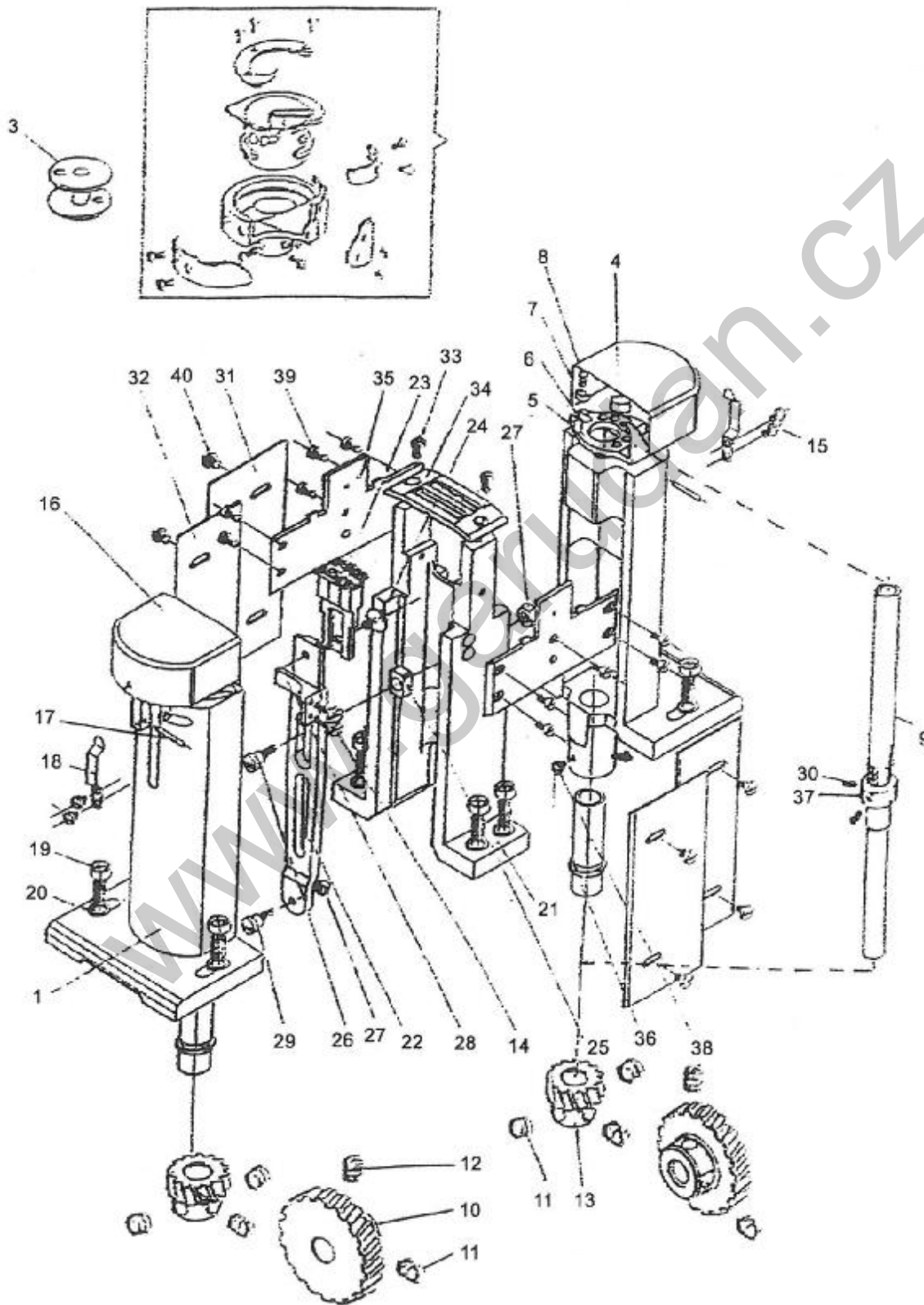

H.Hook saddle mechnism

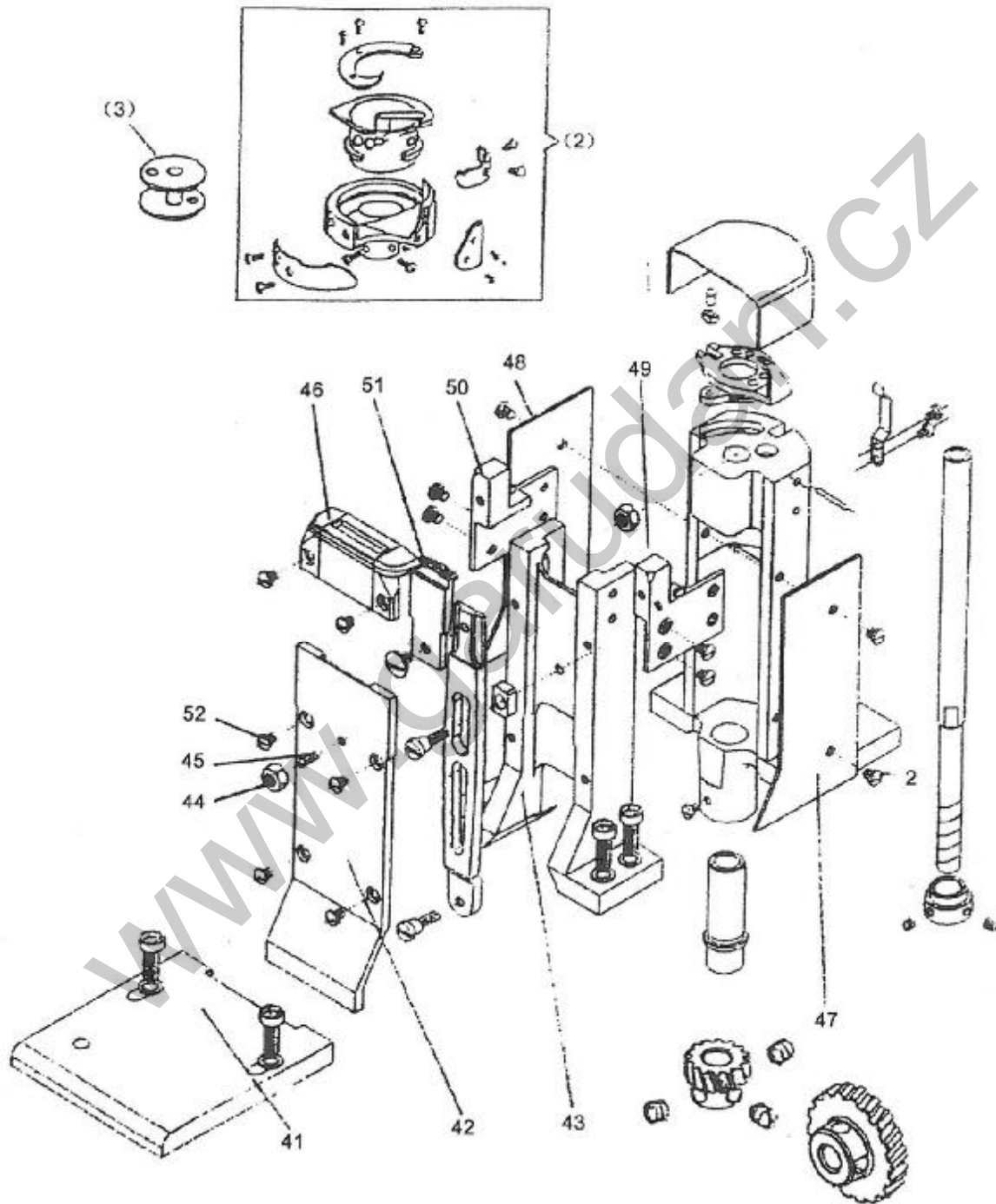

H.Hook saddle mechnism

Fig. No.	Part No.	Description	GP-230-43 MH	GP-130-43 MH	Remark
H01	7021315101	Hook saddle	2	1	
H02	70202150	Hook Assy.	2	1	
H03	70221280	Bobbin	2	1	
H04	70216115	Felt (upper)	2	1	
H05	70202158	Hook thread distributing claw (middle)	2	1	
H06	70202151	Hook opener	2	1	
H07	70212038	Slide block	2	1	
H08	70210159	Pin	2	1	
H09	70203110	Hook shaft	2	1	
H10	70207031	Hook saddle gear (big)	2	1	
H11	70215248	Screw	2	1	1/4 (40) × 6
H12	70215049	Tighten screw	2	1	1/4 (40) × 6.5
H13	70207030	Hook saddle gear (small)	2	1	
H14	70215250	Screw	4	2	11/64 (40) × 10
H15	70215252	Screw	4	2	1/8 (44) × 3.5
H16	70202154	Hook cover Assy.	2	1	
H17	70210161	Pin	2	1	
H18	70217182	Spring plate	2	1	
H19	70215312	Screw	8	8	M6×1×20
H20		Washer	8	8	
H21	70213150	Double needle bracket	1		
H22	70211113	Feed plate	1	1	
H23	70202162	Feed dog	1		3/16
H23	70202156	Feed dog	1		3/8
H23	70202160	Feed dog	1		1/2
H24	70215133	Screw	1	1	11/64 (32) × 6.5
H25	70212100	Feed plate slide block	1	1	
H26	70215580	Screw	1	1	3/16 (28)
H27	70215519	Nut	2	2	3/16 (28)
H28	70211114	Block	1		
H29	70210160	Feed crank hinge shaft	1	1	3/16 (20)
H30	70215122	Screw	4	2	1/4 (40) × 6
H31	702111101	Lower side plate (left)	2		
H32	7021111201	Lower side plate (right)	2		
H33	70215154	Screw	2		9/64 (40) × 10
H34	70202163	Needle plate	1		3/16
H34	70202155	Needle plate	1		3/8
H34	70202161	Needle plate	1		1/2
H35	70211108	Upper side plate	1		3/16
H35	70211110	Upper side plate	1		3/8
H35	70211109	Upper side plate	1		1/2
H36	70208180	Hook bushing	2	1	
H37	70209025	Collar	2	1	

H.Hook saddle mechanism

Fig. No.	Part No.	Description	CP-230-43 MH	CP-130-43 MH	Remark
H38	70216059	Copper oiling nozzle	2	1	
H39	70215253	Screw	10	4	9/64 (40) × 12
H40	70215157	Screw	8	4	11/64 (40) × 4
H41	7021111501	Plate		1	
H42	7021111601	Cover plate (left)		1	
H43	70213152	Single needle bracket		1	
H44	70215581	Adjustive nut		1	11/64 (40)
H45	70215581	Adjustive screw		1	11/64 (40) × 7
H46	70202165	Single needle plate		1	
H47	702111701	Cover plate (front)		1	
H48	7021111801	Cover plate (back)		1	
H49	70213153	Needle plate assembly saddle (front)		1	
H50	70213154	Needle plate assembly saddle (back)		1	
H51	70202166	Feed dog (single needle)		1	
H52	70215121	Tighten screw		10	11/64 (40) × 12

I.Oiling mechanism

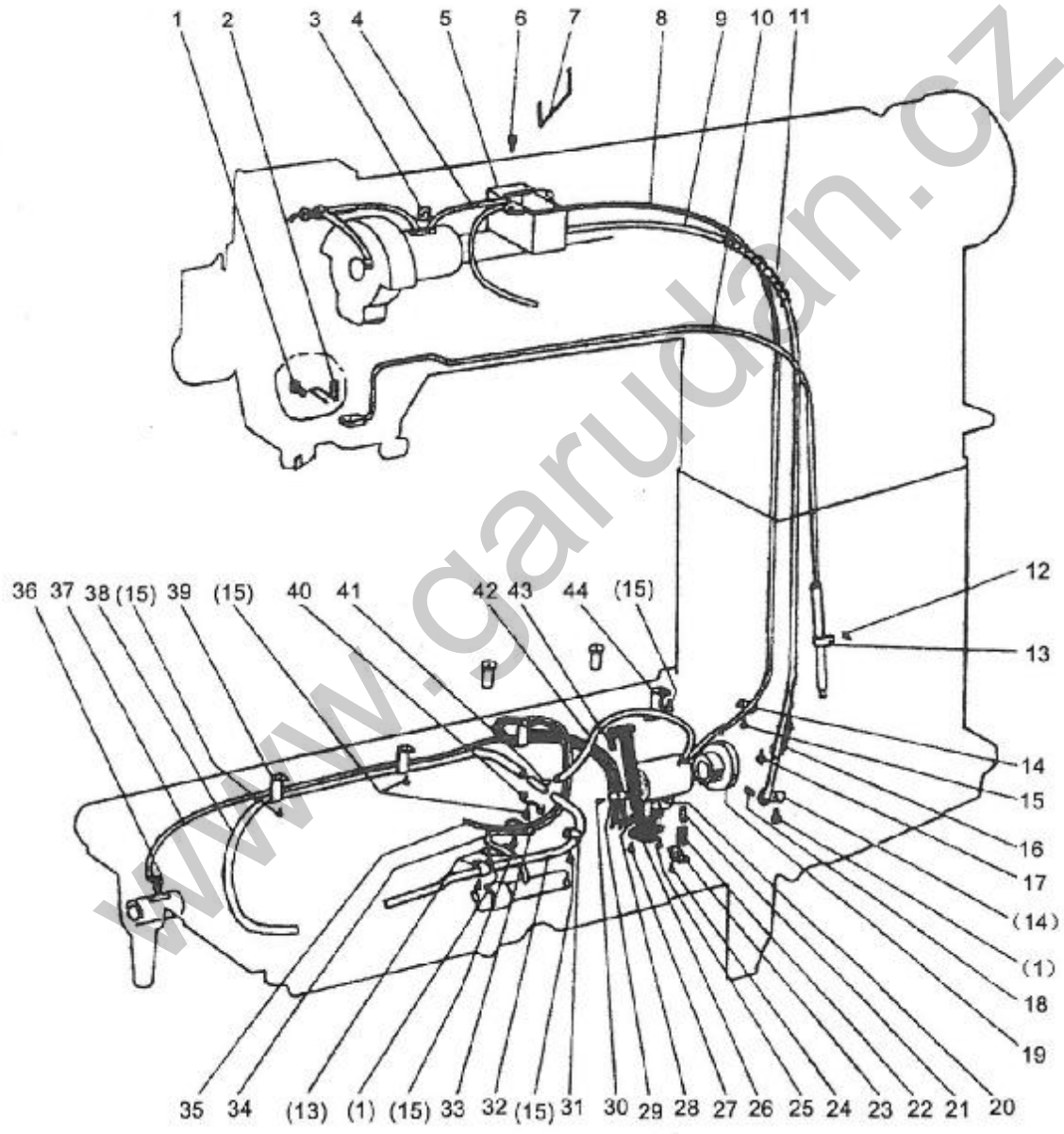

I.Oiling mechanism

Fig. No.	Part No.	Description	GP-230-443 M/H	GP-130-443 M/H	Remark
101	70215121	Screw	3	3	11/64 (40) × 8
102	70217051	Oil tube clamp	1	1	
103		Felt	1	1	
104		Oil tube Assy.	1	1	
105	70216046	Oil box Assy.	1	1	
106	70215256	Screw (galvanization)	2	2	
107	70217047	Oil tube clamp	1	1	
108	70216047	Oil tube $\phi 3 \times 1 \times 580$	1	1	
109	70216048	Oil tube $\phi 5 \times 1 \times 540$	1	1	
110		Oil tube Assy.	1	1	
111		Oil tube spring	2	2	
112	70215250	Tighten screw	7	7	9/64 (40) × 6.5
113	70217029	Fixed clamp	1	1	
114	70217048	Oil tube clamp	2	2	
115	70215160	Screw	6	6	11/64 (40) × 5.5
116	70217057	Oil tube clamp	1	1	
117	70215250	Back cover screw Assy.	1	1	11/64 (40) × 9
118	70215251	Tighten screw	2	2	11/64 (40) × 10
119	70208081	Bushing	1	1	
120		Oil tube	1	1	
121	70210056	Post plug	1	1	
122	70217055	Spring	1	1	
123	70211047	Block plate	1	1	
124	70215252	Screw	1	1	1/8 (44) × 4.8
125	70215253	Screw	1	1	9/64 (40) × 5
126	702111048	Filter plate	1	1	
127	70215253	Screw	1	1	9/64 (40) × 7
128	70211049	Oil tube plate Assy.	1	1	
129	70217058	Oil tube clamp	1	1	
130	70215250	Screw	1	1	9/64 (40) × 6
131	70211029	Fixed clamp	1	1	
132		Oil tube	1	1	
133	70217047	Oil tube clamp	1	1	
134		Oil tube Assy.	1	1	
135		Oil tube Assy.	1	1	
136		Oil wick	1	1	
137	70216045	Oil tube Assy.	1	1	
138		Oil tube	1	1	
139	70217050	Oil tube clamp	3	3	
140		Oil tube clamp	1	1	
141	70216044	Oiling nozzle	1	1	
142		Oil tube	1	1	
143	70215160	Screw	1	1	11/64 (40) × 10
144		Presser plate	1	1	

J. Accessories

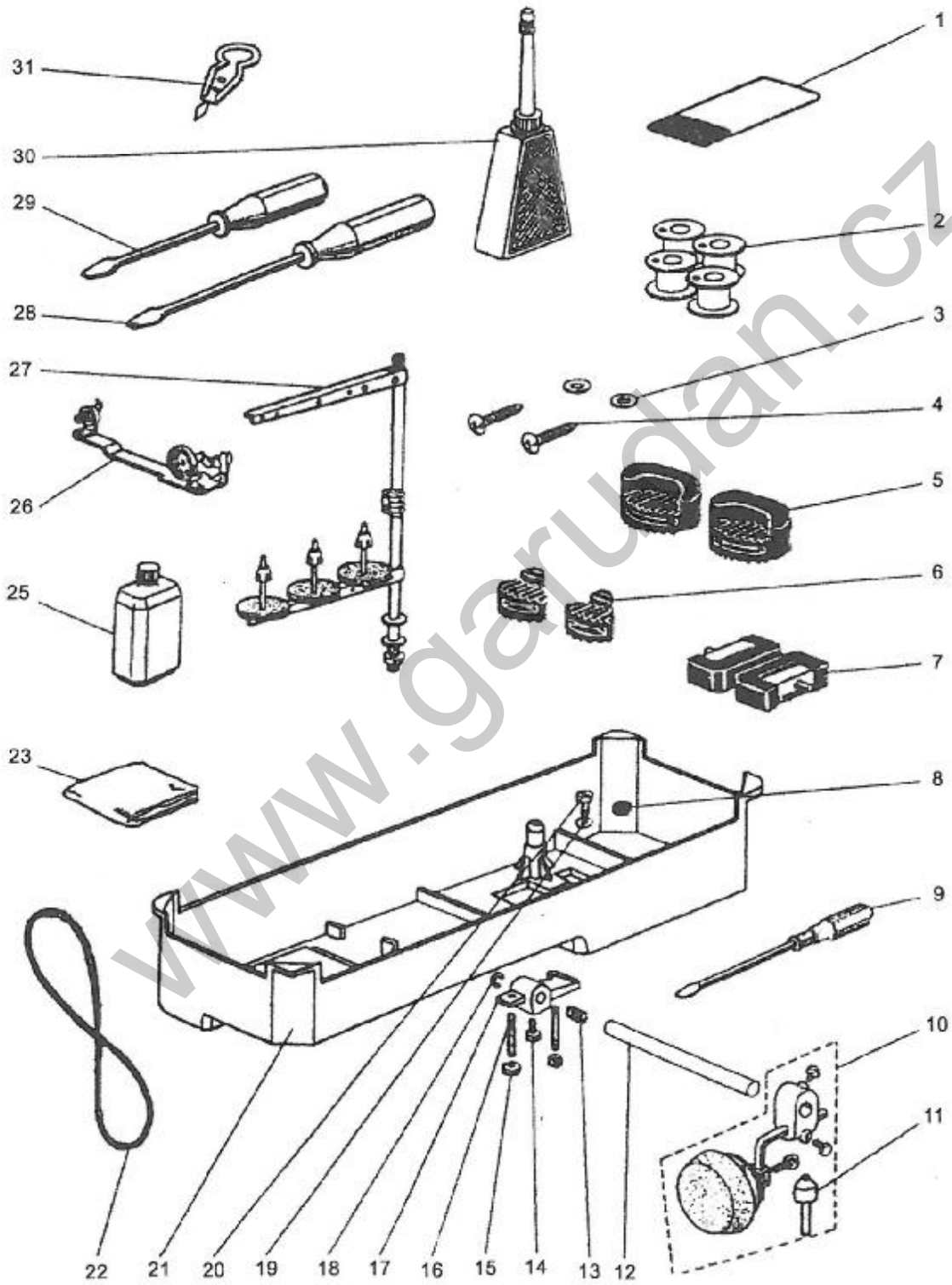

J.Accessories

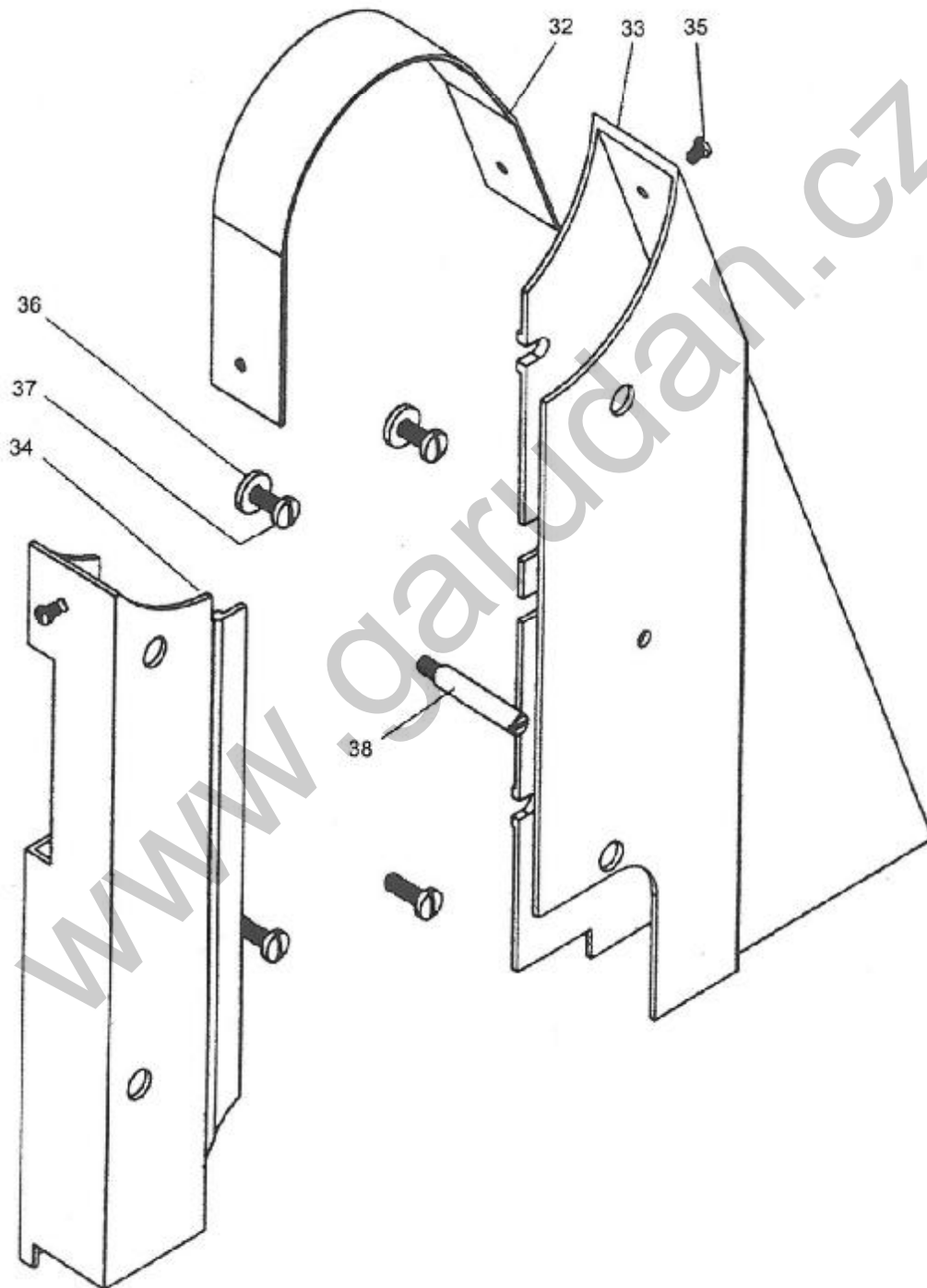

J.Accessories

Fig. No.	Part No.	Description	CP-230-443 MEH	CP 136-443 MEH	Remark
J01	70221072	Needle bag	1	1	DP×17 23#
J02	70221073	Bobbin	4	4	
J03		Washer	4	4	
J04		Screw	4	4	
J05	70221074	Vibration preventing rubber	2	2	
J06	70221075	Vibration preventing rubber	2	2	
J07	70221079	Hinge Assy.	2	2	
J08		Small magnet	1	1	
J09	70221003	Screw driver (big)	1	1	
J10	70221081	Small accessories Assy.	1	1	
J11	70221082	Knee lifter lever Assy.	1	1	
J12	70221083	Knee hinge shaft	1	1	
J13	70221084	Spring	1	1	
J14	70221087	Screw	2	2	15/64 (28) ×28
J15	70221086	Nut	2	2	
J16	70221064	Screw	1	1	15/64 (18) ×13
J17	70221088	Knee lifter level crank	1	1	
J18	70221085	E-ring	1	1	
J19	70221089	Washer	1	1	
J20	70215233	Screw	1	1	5/16 (28) ×10
J21	70221091	Oil pan	1	1	
J22	70221052	Belt M55	1	1	
J23	70221092	Machine head cover plastic bag	1	1	
J25		Oil tank	1	1	
J26	70221048	Thread winding Assy.	1	1	
J27	70280015	Thread stand Assy. 3	1	1	
J28	70221002	Screw driver (middle)	1	1	
J29	70221001	Screw driver (small)	1	1	
J30	70221076	Small oil pot	1	1	
J31		Thread guide Assy.	1	1	
J32	7022128101	Belt cover (upper)	1	1	
J33	70221282	Belt cover (right)	1	1	
J34	70221283	Belt cover (left)	1	1	
J35	70215157	Belt cover (upper) screw	2	2	11/64 (40) ×6.2
J36		Washer	2	2	
J37	70221078	Belt cover screw	4	4	15/62 (28) ×18
J38		Screw	1	1	15/64 (28) ×10